

**RF Block diagram**

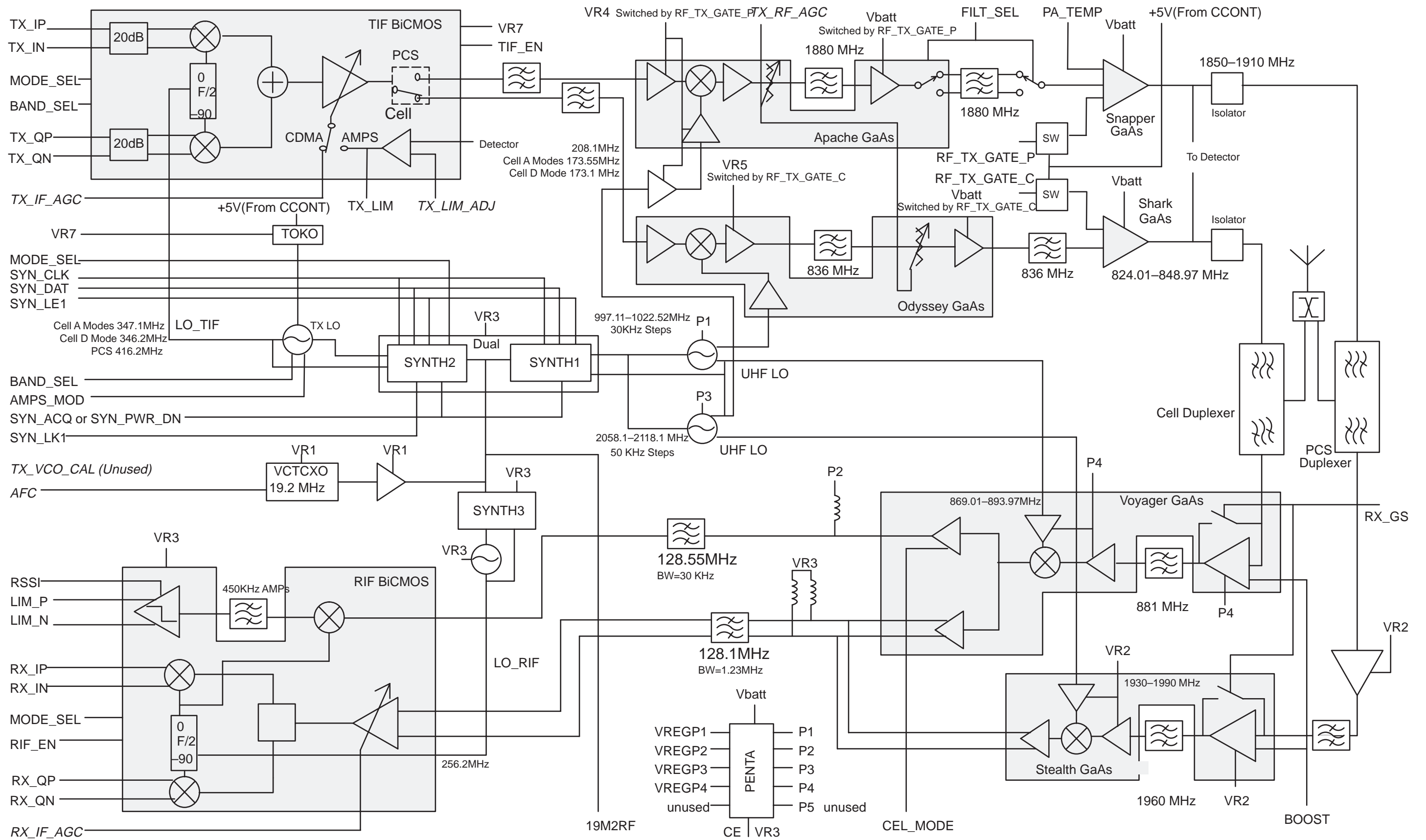

**BB-RF interface** (Version 20a Edition 3) for layout version 20

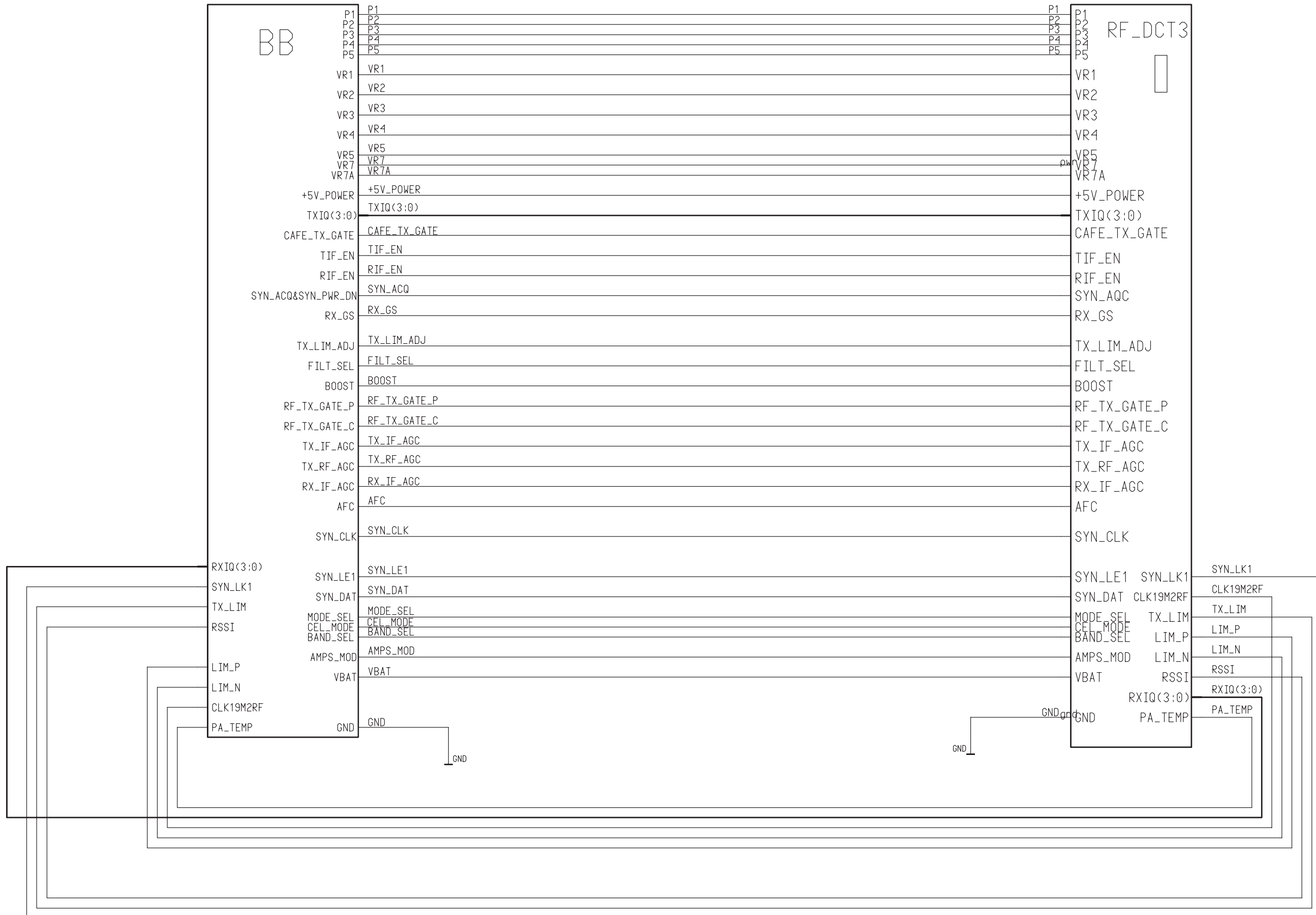

**Circuit Diagram of BB** (Version 20a Edition 3) for layout version 20

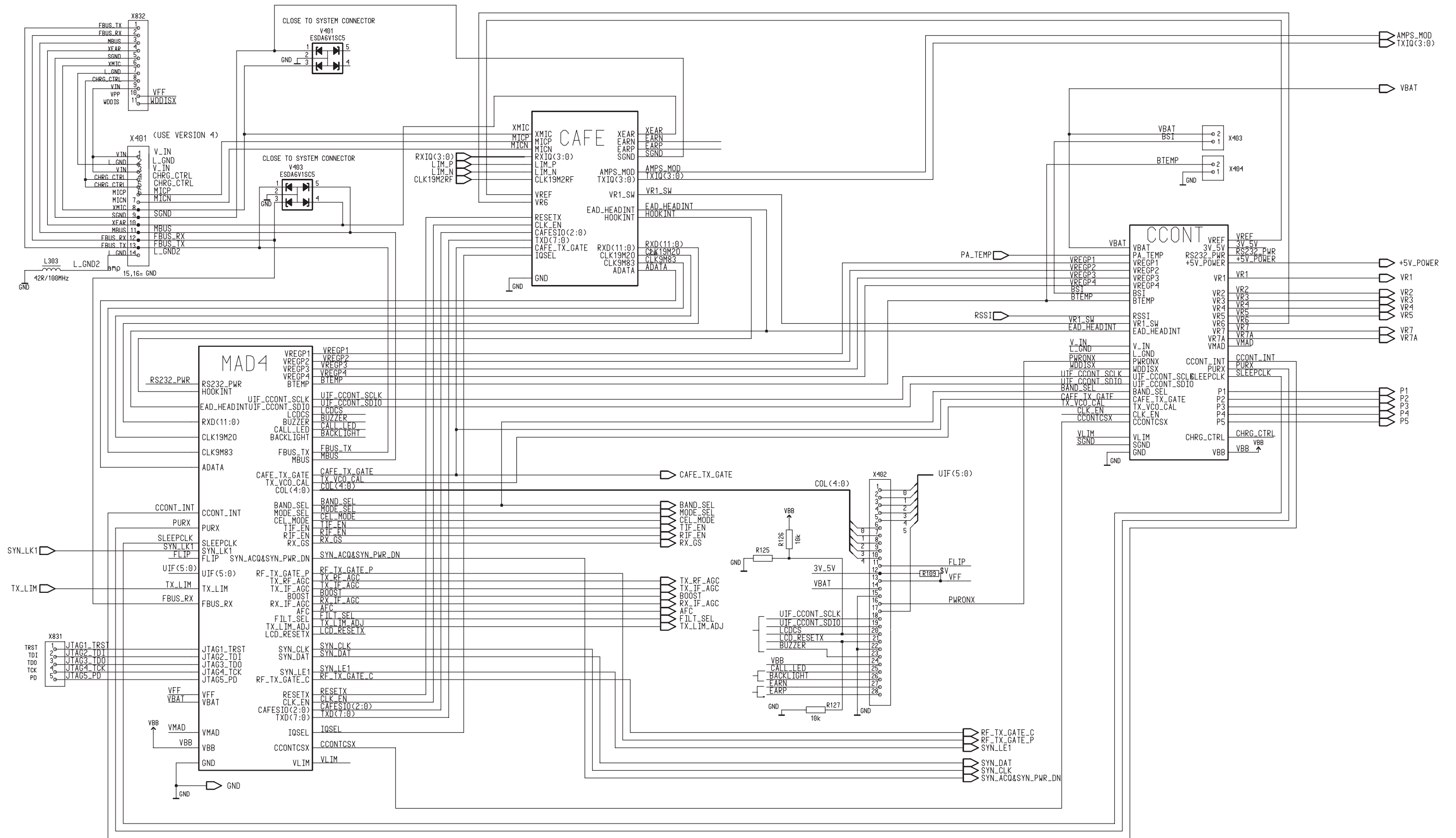

**Circuit Diagram of Power Supply** (Version 20a Edition 9) for layout version 20

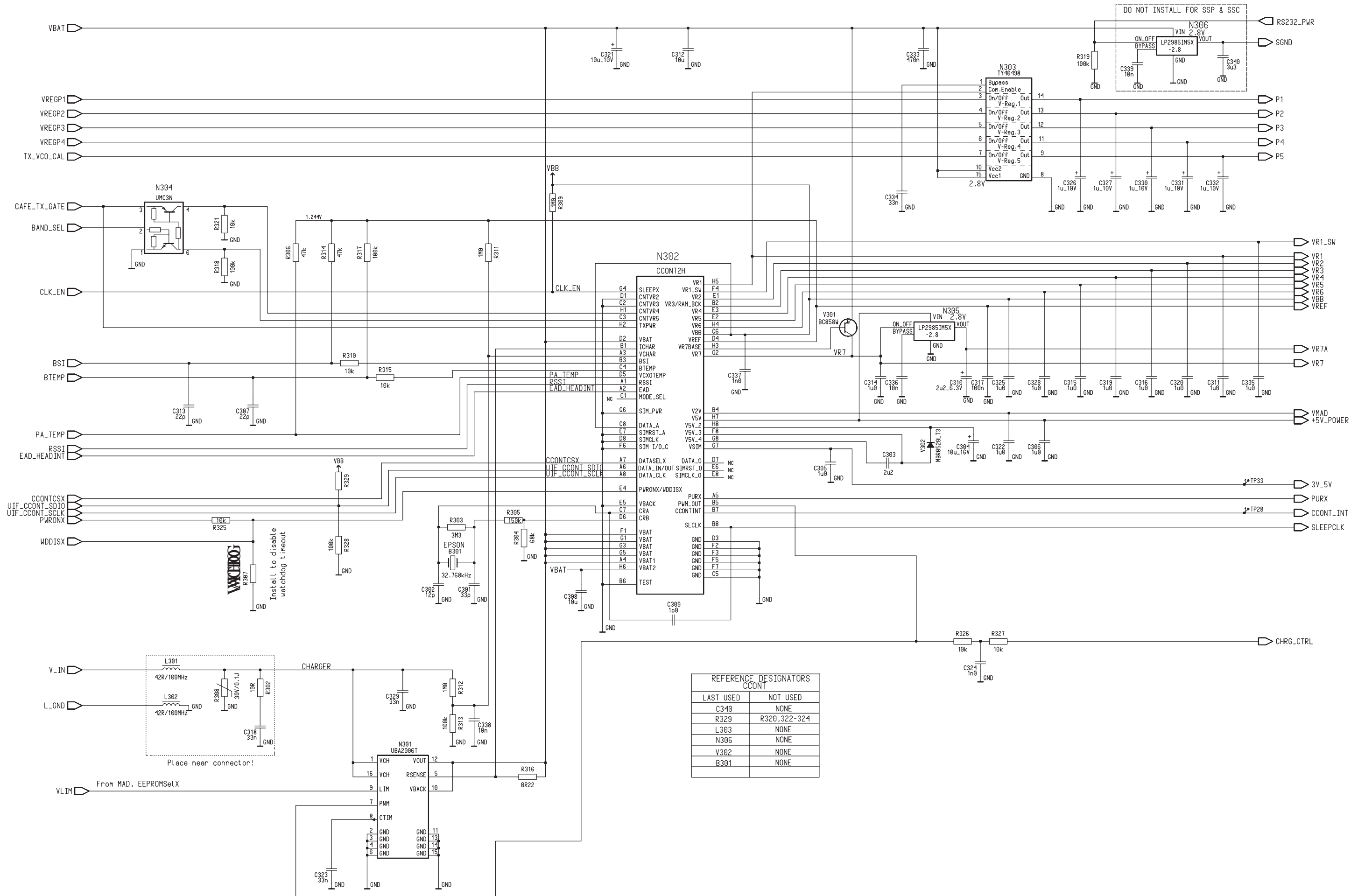

**Circuit Diagram of RF Block** (Version 20 Edition 3) for layout version 3

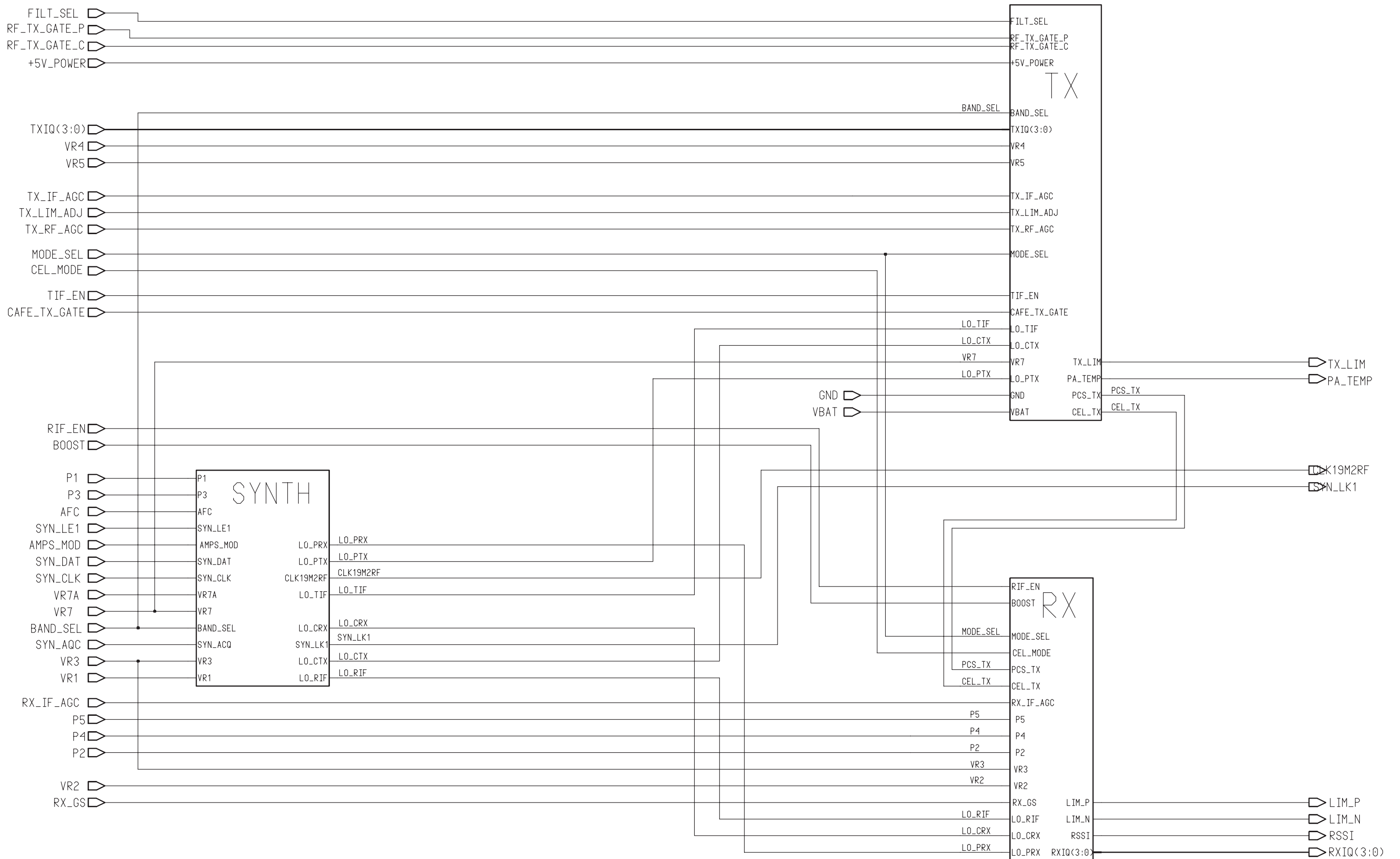

**Circuit Diagram of RX** (Version 20a Edition 4) for layout version 20

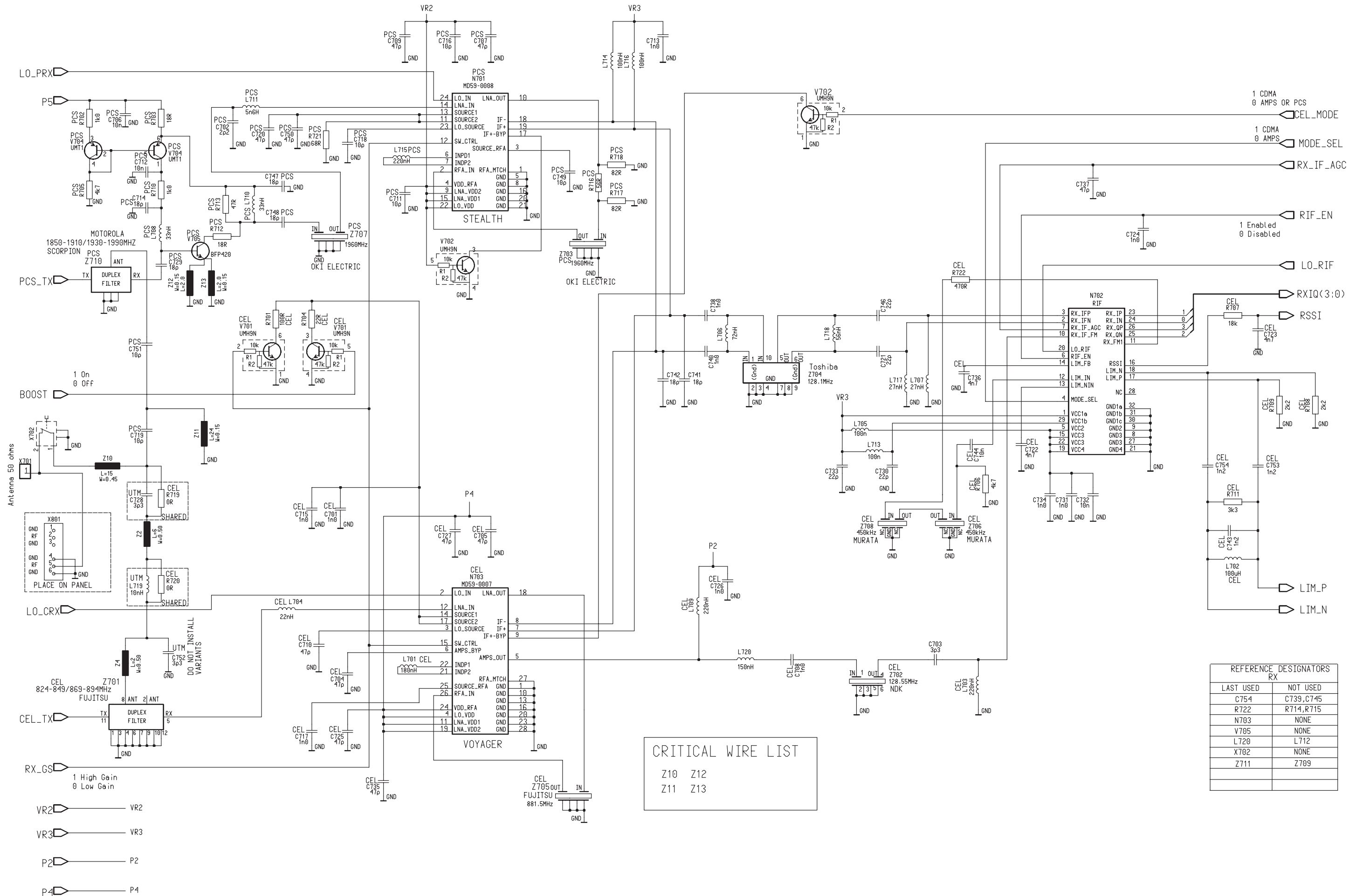

**CRITICAL WIRE LIST**

Z10	Z12
Z11	Z13

**REFERENCE DESIGNATORS**

RX	
LAST USED	NOT USED
C754	C739, C745
R722	R714, R715
N703	NONE
V705	NONE
L720	L712
X702	NONE
Z711	Z709

**Circuit Diagram of TX** (Version 20a Edition 8) for layout version 20

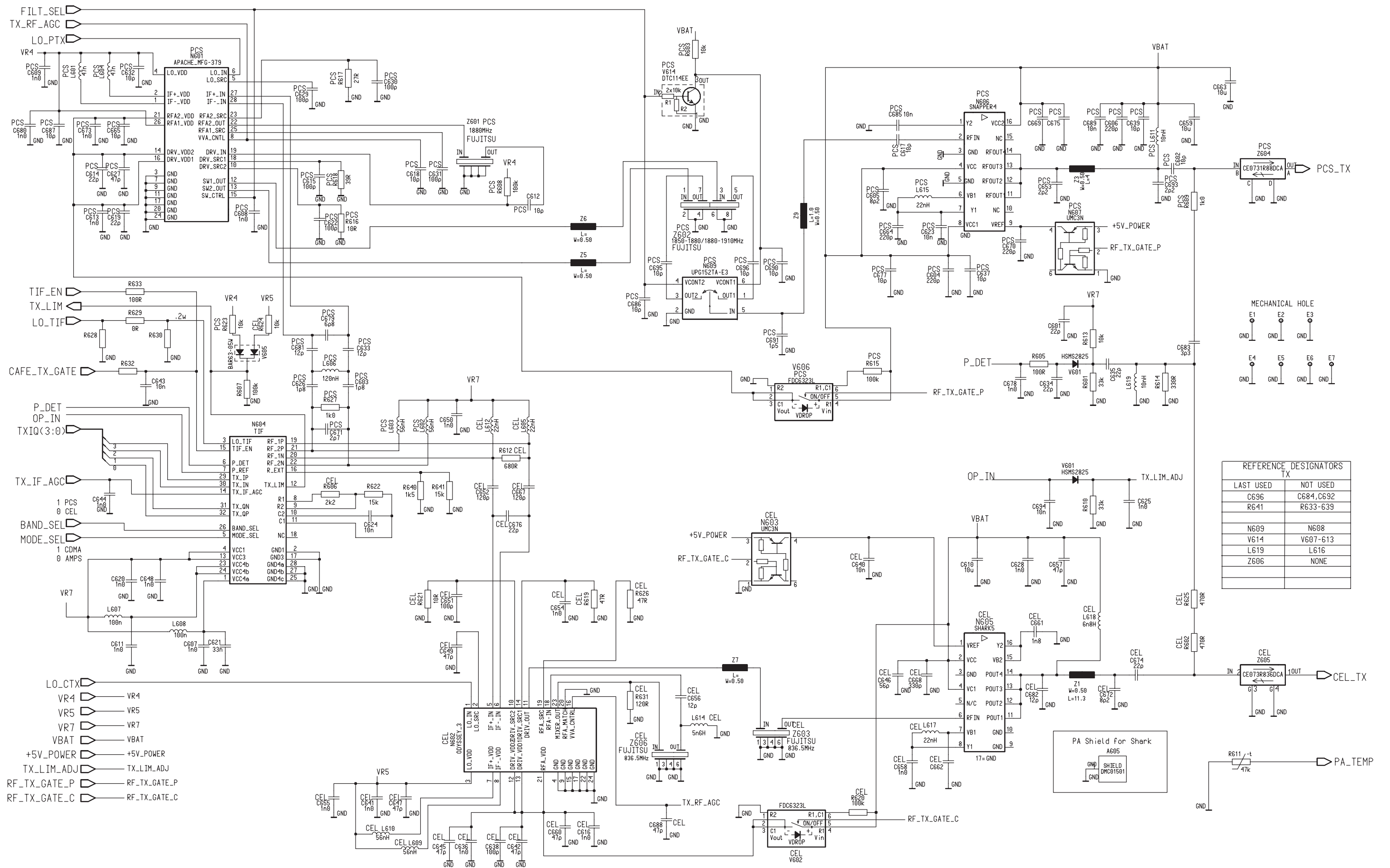

REFERENCE DESIGNATORS	
TX	
LAST USED	NOT USED
C696	C684, C692
R641	R633-639
N609	N608
V614	V607-613
L619	L616
Z606	NONE



**Circuit Diagram of Synthesizer** (Version 20a Edition 5) for layout version 20

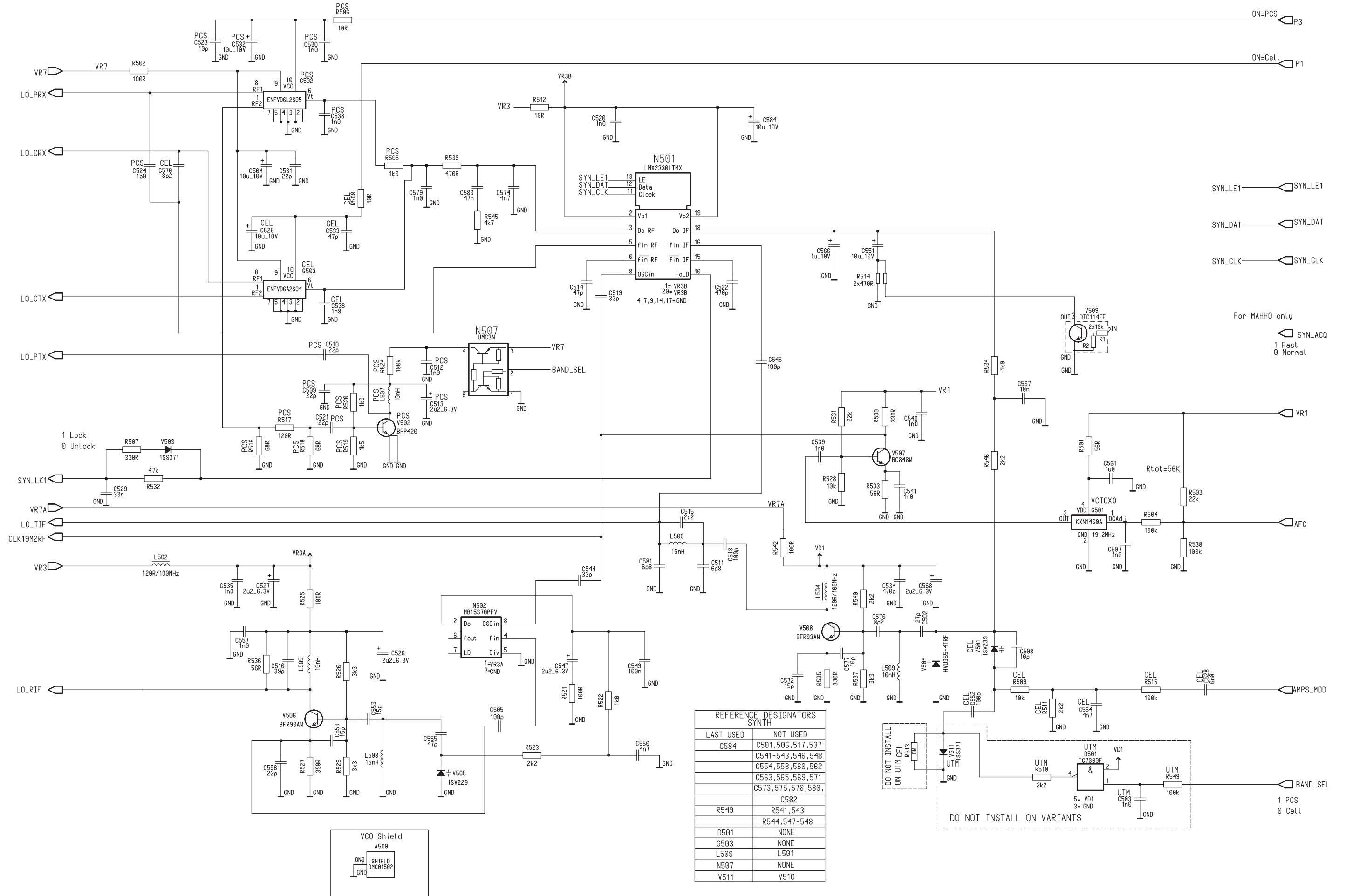

REFERENCE DESIGNATORS SYNTH	
LAST USED	NOT USED
C584	C501, 506, 517, 537
	C541-543, 546, 548
	C554, 558, 560, 562
	C563, 565, 569, 571
	C573, 575, 578, 580,
	C582
R549	R541, 543
	R544, 547-548
D501	NONE
G503	NONE
L509	L501
N507	NONE
V511	V510



**Circuit Diagram of Cafe** (Version 20a Edition 5) for layout version 20

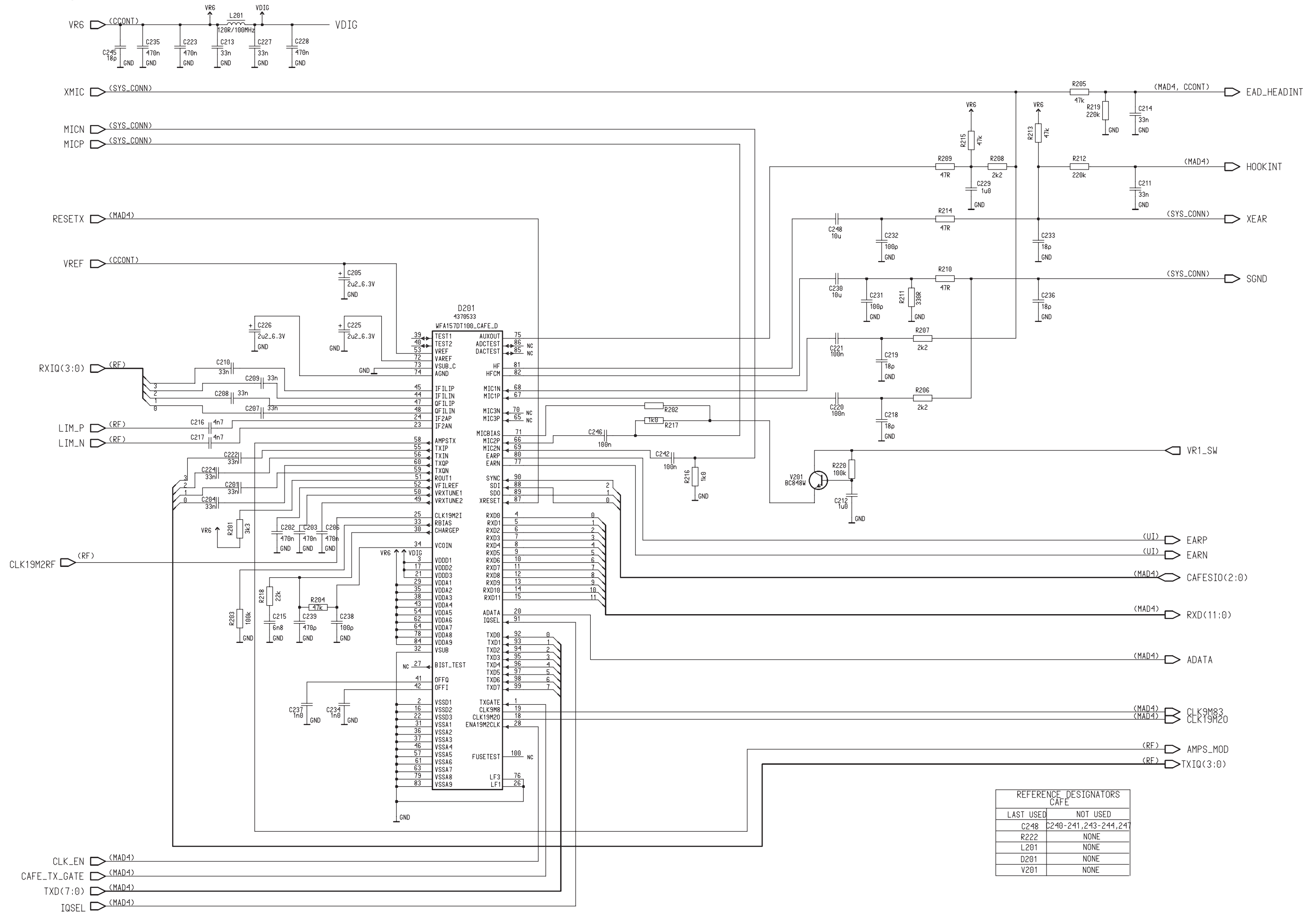

REFERENCE DESIGNATORS CAFE	
LAST USED	NOT USED
C248	C240-241,243-244,247
R222	NONE
L201	NONE
D201	NONE
V201	NONE



**Circuit Diagram of MAD4 External Memories** (Version 20a Edition 4) for layout version 20

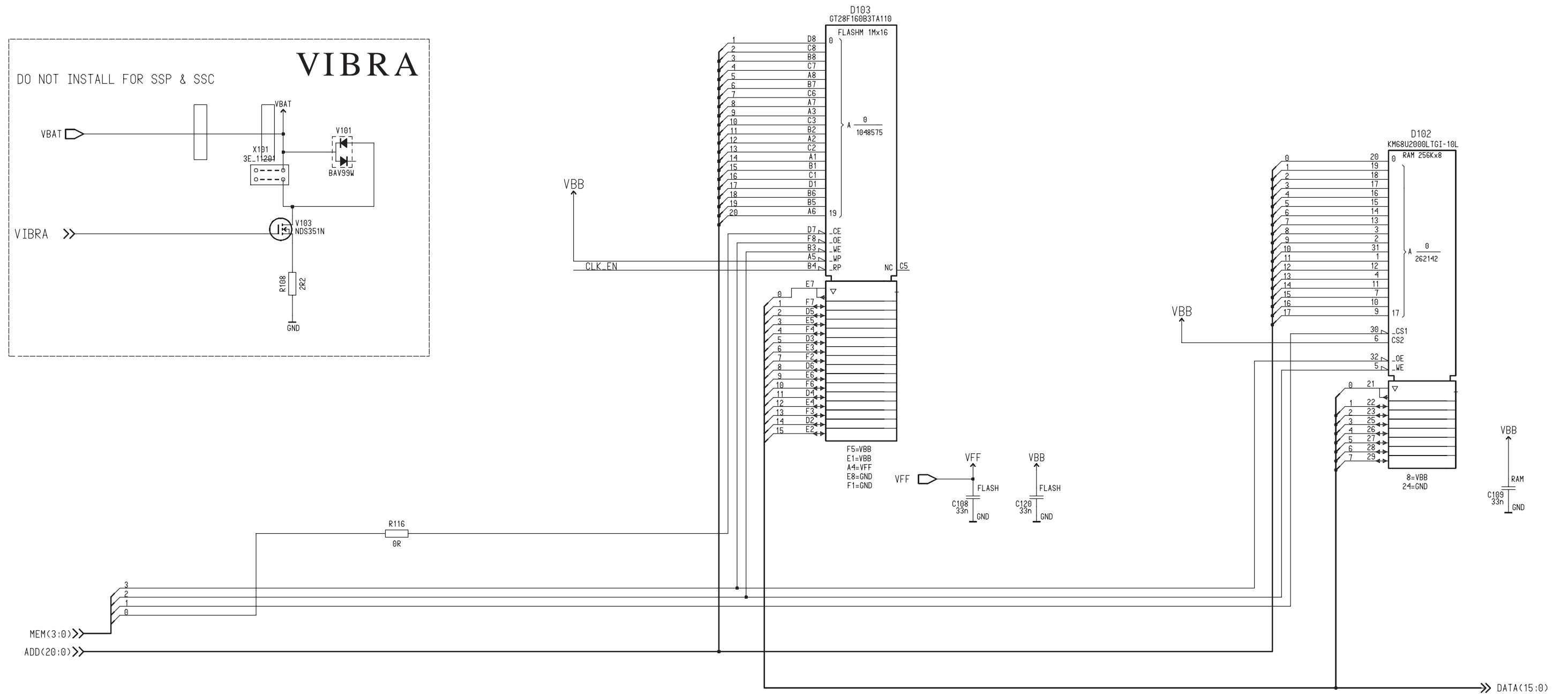

**Layout Diagram of UF4D – Top (Version 20)**

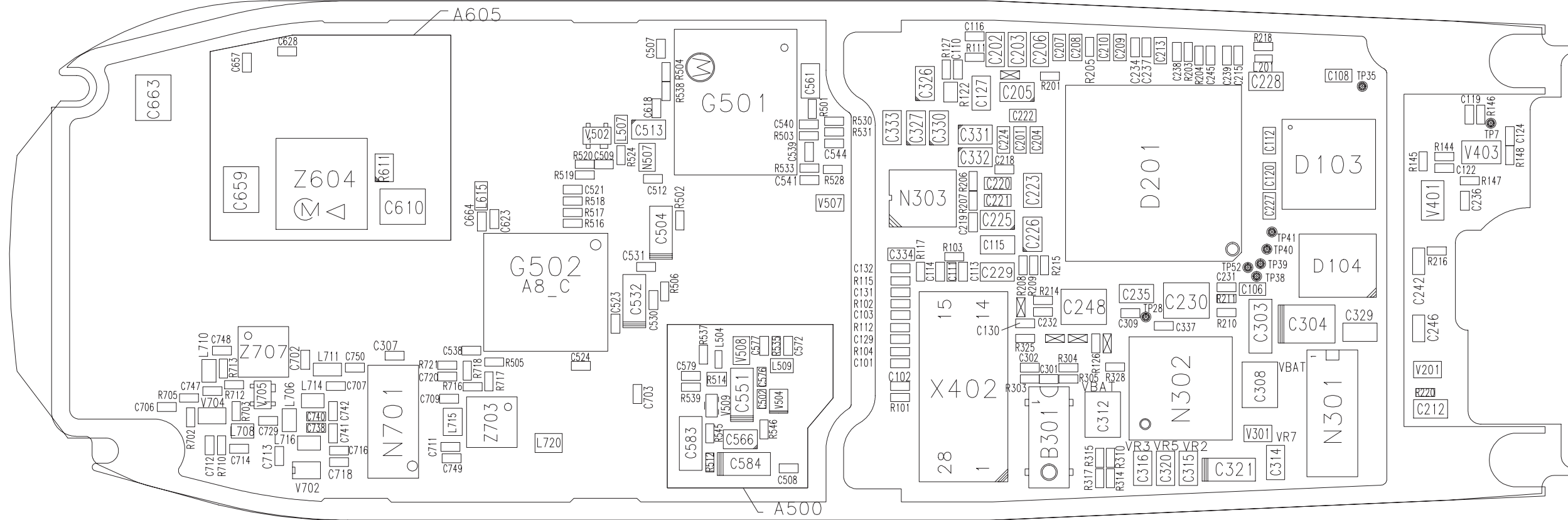

**Layout Diagram of UF4D – Bottom (Version 20)**

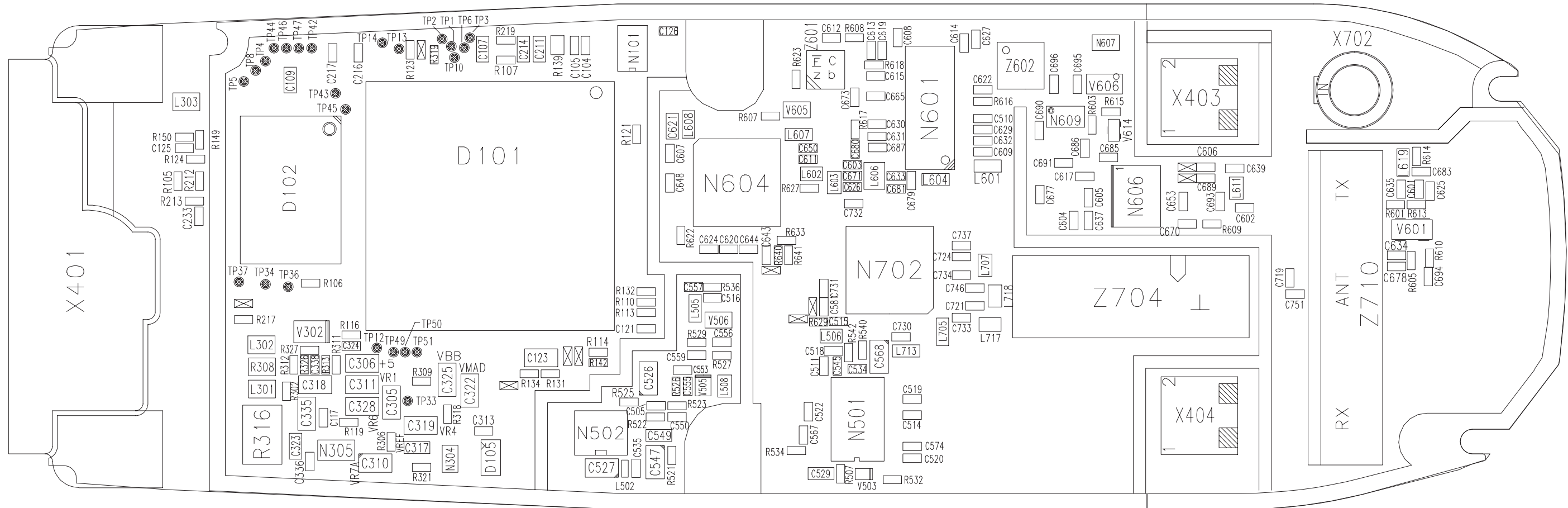

**RF Troubleshooting Test Points for UF4D – Top (Version 20)**

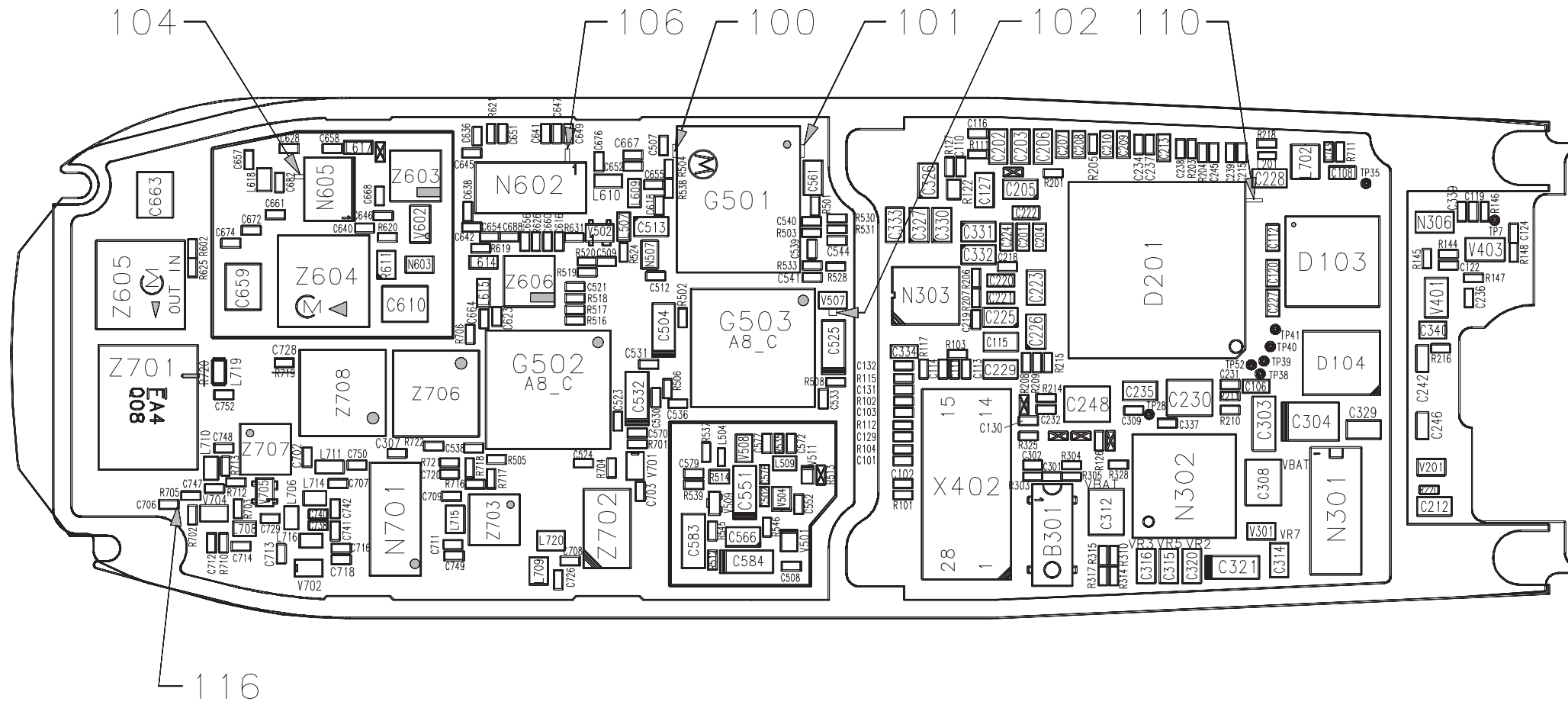

**RF Troubleshooting Test Points for UF4D – Bottom (Version 20)**

